

MACHINES FOR FLUID DOSING AND TREATMENT



CASTING MACHINES FOR 2K RESINS

M-DUO-HP

FLUID DOSING COMPONENTS



FLUID DOSING SYSTEMS AND INTEGRATED SOLUTIONS



TM reserves the right to change technical data, pictures or technical descriptions without prior notice.

TM srl • Via Cicogna 12-14
40068 San Lazzaro di Savena (BO) Italy
Tel. +39 051 6511012 • Fax: +39 051 796966
E-mail: tm-italia@tm-italia.it • www.tm-italia.it

REV. 01



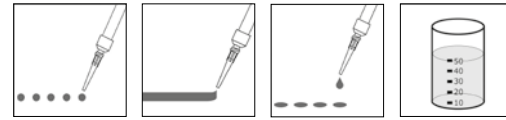

Suitable for dispensing applications of:

Silicone, polyurethane or epoxy based viscous resins.

Semi-automatic dispensing machine for medium or high viscosity 2K resins. Suitable for casting applications with polyurethane, epoxy or silicone resins, with or without the presence of suspended abrasive fillers (after evaluation of the technical data sheet and product sample). The basic machine doses by means of a dispensing valve combined with a disposable static mixer. The machine has a painted steel structure housing the two extrusion pumps, the electrical panel and the dosing system. In the machine there are two independent tanks containing respectively the resin and the hardener. Cycle start by means of a trigger or external if the dispensing head is mounted on an automation. In the basic configuration there is no automatic degassing of the tanks, but the machine can be implemented with an optional kit generating the vacuum. The machine is not designed to handle flammable products, the electrical circuitry is not ATEX compliant. The machine is CE marked and compliant with safety rules and law.

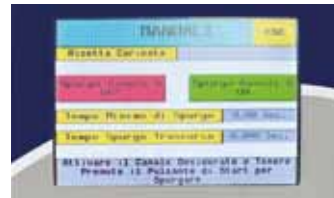

The software

The user-friendly software is able to manage the dosing parameters and the mixing ratio, which could be easily modified through touch screen panel. Possibility to memorize different recipes. On request and after technical verification, it can be implemented with further packages to communicate with the customer's PLC.



The dosing group

The dosing group includes two independent volumetric dosing units with gear-based technology. Particularly suitable for heavy industrial applications of viscous products. High torque and great ability to accurately dose even high viscosity fluids. The products contained in the pails are extruded by means of two independent pressing plate pumps.



The dispensing

The products are dispensed from the valve equipped with a disposable static mixing nozzle. The size of the valve and the model of the nozzle are set up according to the technical specifications of the products to be mixed. The actual maximum flow rate depends on the mixing ratio and the mixing capacity of the static mixer used.

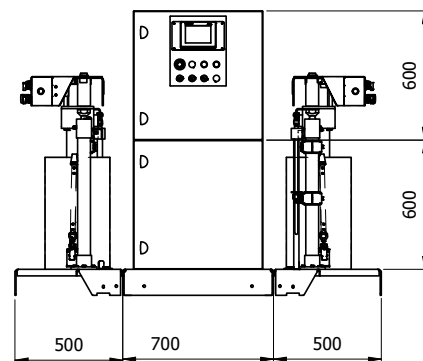

Main technical characteristics

Power supply:	230V 50-60Hz single phase
Auxiliary circuits:	24V DC
Air supply:	5-6 bar
Power:	4 KW indicatively
Standard pneumatics:	SMC or FESTO

Standard models:

The resin dispensing machine M-DUO-HP is equipped with gear-based (DVC) volumetric dosers.

M-DUO-HP 2525	Pump for 25l resin pail – Pump for 5l hardener pail
M-DUO-HP 2505	Pump for 25l resin pail – Pump for 25l hardener pail

Optional software packages

- Industry 4.0 compliance according to customer's specific requirements
- Barcode, QR reader.
- Dialogue with external PLC or supervisor with specified protocols, to be defined in offer

Further optional implementations

- Duct heating: resin tank heating as well as heating of all the pipes up to the dosing head.
- Optional gun handle with integrated trigger control.
- Balanced pantograph arms.



Electronic circuits potting.



Dispensing on micro switches.

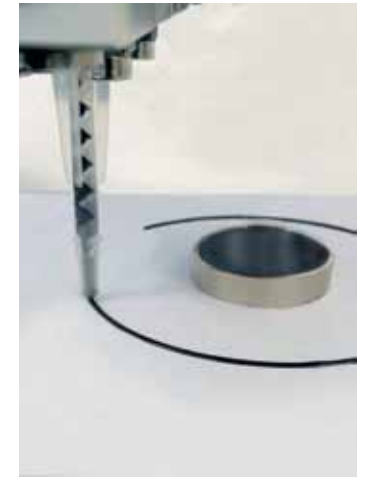

Curbs creation.



Potting on connectors.



Balanced pantograph arm.

APPLICATIONS

M-DUO-HP machines can be used in many dispensing and dosing applications and assembling processes. Typical applications are:

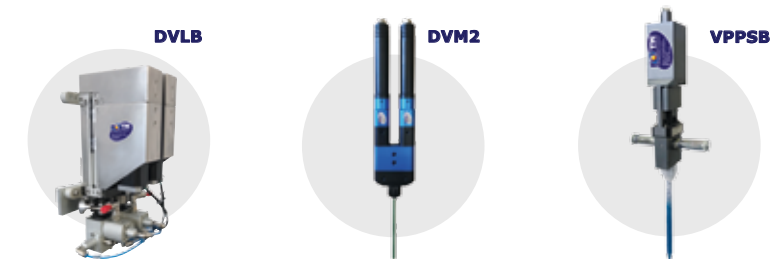

SEALING

Liquid sealing and liquid gaskets for electronics and engine assembly. Typical application sees the machine equipped with volumetric electric continuous dosers gear-based such as the DVC series.

RESIN CASTING/POTTING

Potting, casting or injection of 1k or 2k resins for electronic elements and PCBs. Typical application sees the machine equipped with volumetric electric linear piston-based or screw-based dosers, such as DVL or DVM series.

FILLING

Dosing and precision filling of oleodynamic or mechanical cinematics. Typical application sees the machine equipped with volumetric electric linear piston-based dosers such as the DVL series.

BONDING AND HEAT TRANSMISSION

Structural bonding of parts. Typical application sees the machine equipped with volumetric electric linear piston-based or screw-based dosers such as DVL or DVM series

MICRODOSING

Microdosing of lubricants during mechanical assembly process, which can be contact, contactless or microspray. Typical application sees the machine equipped with volumetric pneumatic dosers such as the VVPP or VVAP series.